

ISRA Rulebook 2011

Last updated 2011-03-29

Definitions

Penalties

1. General Principles

2. Tracks and speed controllers

3. Event procedure

Prior to race procedures

Production Race Procedure (1/24 Production)

Sprint race procedure

4. Technical Specifications

Production 1/24

Eurosport 1/32

Formula 1/32

Eurosport 1/24

5. Local Rules

6. Product eligibility and homologations principles

Definitions

The ISRA World Championships (ISRA WC) is defined as the whole event including practice sessions, meetings and four races.

A race is defined as a competition measured from the beginning of the technical inspection until the end of the final stage of that competition. The ISRA WC consists of four races.

A class is defined as a technically specified car to be used. A race always runs one class only. Qualifying, warm-up, heats, semi-finals and the final are seen as stages of a race.

Group/groups are used as the division of a stage following the results of qualifying or earlier stages of the race.

A segment is defined as one of eight time periods of driving in a group.

An entrant is a person who has enrolled, paid the entry fee and ISRA license, and is participating in any of the ISRA WC races and their practice sessions.

A driver is an entrant who has had her/his car passed in the technical inspection at the beginning of a race.

The Race direction is the responsible body for the ISRA WC from start to end. The race direction relies on the Race Jury for rule interpretation. Only the Race direction can enforce penalties (section 1.8). Penalties can only be given to entrants.

An ISRA delegate is the representative of a country that has entrants, or has had entrants in an ISRA WC during the last 3 years. The delegates are obliged to participate in the ISRA delegates meeting and if elected be part of the Race Jury (section 1.2).

A driver's nationality is based on her/his valid passport. Only nations accepted within the United Nations are considered nations within ISRA.

Penalties

- a) Illegal track call: - 2 laps.
- b) Missing marshalling duties in practice: - Loss of the next practice session.
- c) Missing last marshalling duty in practice: - Loss of the best qualifying time.
- d) Missing marshalling in race: - 10 laps.
- e) Accidental crash on the straight in front of the drivers, caused by a driver's hand or a car in hand, or a touch of another driver's car by a pit crew member while removing or replacing a car in the pit zone: - 10 laps. If it happens in another place of the track the penalty in k/ below is added.
- f) A car returned to the enclosed park after the closing of technical inspection: - 10 laps.
- g) Unsportsmanlike conduct: - "The use of obscene and foul language on any occasion constitutes unsportsmanlike conduct" - For the first infraction - warning, for second infraction - 10 laps, for third infraction - disqualification.
- h) Practising on another entrant's turn or driving another driver's car during racing is considered unsportsmanlike conduct. In the case of practising it also renders in the loss of the entrant's next practice session. If it happens in the last practice round it will result in the entrant missing the best qualifying time in the sprint races and the loss of one (1) lap in the qualifying in the production team race.
- i) Use of illegal parts: - "Regardless of whether the car has passed a previous technical inspection" - Disqualification.
- j) Driving with an illegal car: 3 laps for every lap made from when the race controller recorded the car as illegal. When the car is repaired it must be re-teched before being returned to the track
- k) A repaired car that is put on the track elsewhere than the designated pit area: - 3 laps.

- l) Use of illegal chemical substance at all times, - 10 laps. The use of Metylsalicylat (Oil of Winter Green) or any comparable chemical to improve the tire compound renders the driver a penalty of 10 laps in the ongoing stage, or, if found in a technical inspection, the following stage.
- m) Use of tools in lane changes or doing anything other than changing lane sticker, pushing in body pins and straighten braids: - 10 laps.
- n) There must be only one driver/team per car and one car per driver/team during the race: - Disqualification.
- o) For every illegal call, made by a driver there will be a 2-lap penalty imposed.
- p) Deadline for protesting after a race: 5 minutes plus 100 EURO deposit, returnable if protest is upheld

1. General Principles

This section presents the basic principles for the running of ISRA and for staging an ISRA Worlds event:-

- [1.1 The ISRA delegates meeting](#)
- [1.2 The Race Jury](#)
- [1.3 Race direction](#)
- [1.4 Participation](#)
- [1.5 Number of entries](#)
- [1.6 Time frame](#)
- [1.7 Registration](#)
- [1.8 Entry fees](#)
- [1.9 ISRA driver's licenses](#)
- [1.10 ISRA points](#)
- [1.11 Trophies](#)
- [1.12 Racing principles](#)
- [1.13 Marshalling of cars and counting of laps](#)

ISRA Worlds events are presented in the spirit of promoting slot racing world wide. Thus an approved organiser of an event takes on this duty and is preparing and fulfilling an event as a promoter for their national association as well as ISRA as international organisation, and completely in line with the decisions made by the ISRA Delegates.

Every ISRA World Championships event must be organised and staged under the authority of the association of ISRA world delegates. Those countries wishing to stage the ISRA World Championship must submit a written proposal to the acting ISRA chairman. The sites for the Championships will be announced at least two years in advance. Only those persons who are licensed by ISRA may take part in these events. The licence fee is to be paid together with the entry fees, and a number be issued at registration. A license number is required for taking part in any practice session. The total number of licenses granted worldwide is unrestricted.

1.1 The ISRA delegates meeting

[Up](#)

At the ISRA World Championships a preparatory ISRA delegates meeting shall be held on the Sunday evening. During the meeting shall the following issues be decided or presented:

- a) The election of a Race Jury for the event according to section 1.2 of the rulebook. There will be a short meeting (15 minutes) on the Saturday before the Production 24 race to appoint the race officials.
- B) Proposals for changes to the ISRA rulebook for the following year's event.
- c) Proposals of coming events.
- d) Other questions to be considered by the delegates.

Proposal and suggestions can be submitted in advance to the ISRA Chairman or presented at the ISRA-meeting at b/. Questions raised in b and c/ shall be decided during a Delegates meeting held at the end of the event (Saturday).

At the Delegates meeting the following issues will be decided upon: -

- a) Election of officials; ISRA chairman, ISRA secretary or ISRA technical officer.
- b) Election of an election committee consisting of two delegates for the following year.
- c) Evaluation.
- d) Coming events.
- e) Changes to the ISRA rulebook for the following year's event. There is a deadline of the first week of December for changes to the rule book, plus one week for delegates response
- f) Other questions.

The election of officials is for three (3) years. The sequence is Secretary (2011), Technical officer (2012), Chairman (2013). Each of these officials has a deputy. The election committee must present a proposal for a new official the latest 30 days prior to the Delegates meeting. Proposals from individual licensed drivers can be submitted directly to ISRA within the same time frame. A proposed person must know they are submitted and be approached by ISRA to be able to acknowledge if they are willing to take on the duty. The choice will be from these candidates. To be selected a majority of votes is necessary (50%). If none of the candidates receives 50% of the votes; the two with most votes enter a second

voting round. In case of equal number of votes in the second round the Chairman of the meeting has a decisive vote. A person cannot vote in an election in which he/she is a candidate.

Voting shall always be conducted by showing of hand.

The organiser of an ISRA World Championship shall always conduct an evaluation among the drivers during the championships. The results of the evaluation will be discussed at the Delegates meeting the last day of the ISRA WC, and before the official closing of the championships.

The ISRA delegates can decide that a question brought up at the official meeting shall be decided through an e-mail vote between the delegates. The chairman always conducts such a procedure.

The minutes from both these meetings will be published on the ISRA website; www.isra-slot.com

1.2 The Race Jury

At the ISRA World Championships, the Race Jury will consist of the Race Director plus 4 delegates (2 voted by delegates + 2 chosen by the Race director.). The jury will handle and solve all issues with regard to rule interpretation, disqualification, lap counter or track failures, etc. A Deputy will step in if a Steward is personally involved in or affected by a dispute. A deputy may also step in if a Steward is unavailable due to illness or else.

1.3 Race direction

A race direction must consist of a Race Director controlling the event (as a whole), a Race Controller running the races, a Technical Director responsible for the inspections and the pit-area, and a Result Manager running the result services. These four officials cannot be drivers at any stage of the event. If any of them is enrolled as a participant in a class, then, in that class, a Non-racing deputy official must be appointed. The persons filling these positions must be presented on the official website 60 days prior to the event.

1.4 Participation

An "Olympic rule" is used which means that all nations are welcome to participate with entrants.

1.5 Number of entries

Maximum entrants: everybody is welcome to race, but if the number of total entries with host nation racers included exceeds 104 the host nation can enrol the same number of drivers of the largest delegation, if the number of entries is lower than 104, host nation can fill up the field till 104 racers.

There is no restriction of the number of teams in the Production team race.

The organiser has to plan for a minimum number of 64 teams in the production team race, and 104 drivers in the sprint races. (See section 1.6 below for time schedule and steps to take if numbers exceeds 64/104)

Due to concerns of the race duration the race direction may, together with the race jury, decide to alter the driving times in section 3.2.2 and 3.3.2.

1.6 Time frame

Race Day	Time	Activity	Duration (*)	Note
1 Friday	10.00 - 13.00	free practice prod24	3h	ticket system
	13.00 - 16.00	free practice ES32	3h	ticket system
	16.00 - 19.00	free practice F1-32	3h	ticket system
	19.00 - 22.00	free practice ES24	3h	ticket system
	22.00 - 23.00	track prep	1h	track closed
production race 64 team (8 groups)				
2 Saturday	08.00 - 19.00	Practice	2 rounds of 8x4 min per team	Body, tires and motor handout in the morning.
	18.15 - 19.45	Tech	1 h 30 min	
	20.00 - 22.30	Qual	2 h 30 min	track closed
3 Sunday	08.00 - 18.00	Finals 8x7.5 min	10 h	(***)
	19.00 - 20.30	track prep	1 h 30 min	ISRA meeting during track prep
ES32 race 104 drivers (13 groups)				
	21.00 - 23.30	practice	2x4min	track closed
4 Monday	08.00 - 15.00	Practice	6x4 min	
	14.00 - 15.30	Tech	1 h 30 min	(**)
	15.45 - 18.45	Qual	3 h	
	19.00 - 00.00	Heats 8x3 min	5 h	7 heats track closed
5 Tuesday	08.00 - 12.15	Heats 8x3 min	4 h 15 min	6 heats (***)
	13.00 - 16.00	Semis 8x4 min	3 h	
	16.40 - 17.40	Main 8x5 min	1 h	
	17.40 - 18.30	track prep	50 min	
F1-32 race 104 drivers (13 groups)				
	18.30 - 00.00	practice	5x4 min	track closed
6 Wednesday	08.00 - 11.30	practice	3x4 min	
	10.30 - 12.00	tech	1 h 30 min	
	12.15 - 15.15	qual	3 h	
	15.30 - 00.30	heats 8x3 min	9 h	13 heats track closed
7 Thursday	08.00 - 08.30	service break	30 min	(***)
	08.45 - 11.45	Semis 8x4 min	3 h	
	12.30 - 13.30	Main 8x5 min	1h	
		track prep	1h	
ES24 race 104 drivers (13 groups)				
	14.30 - 22.30	practice	7x4 min	track closed
8 Friday	08.00 - 09.15	practice	1x4 min	
	08.15 - 09.45	tech	1h 30 min	
	10.00 - 13.00	qual	3h	
	13.15 - 22.15	heats 8x3	9h	13 heats track closed
9 Saturday	08.00 - 08.30	service break	30 min	
	08.45 - 11.45	Semis 8x4 min	3 h	
	12.30 - 13.30	Main 8x5 min	1h	
	14.30 - 16.30			isra delegates meeting

* The addition of 8 teams (one full final) is 171 minutes (2h 51min) longer duration of the team race. The addition of 8 more drivers in a sprint race adds 96 minutes (1h 36min) to the duration of the race.

** Tech is closed 20 minutes after final practice session seen group by group.

*** "The organizer is responsible for running the track in properly before the start of a morning heat. This has to be done with cars in race condition and of the same class raced.

If the number of entries exceeds 104 the following take effect in steps until the schedule works out:

a/ Practice duration 3 minutes per lane (saves 2 hours per class)

b/ Allow scheduled practice until 2 am (allows 2 more groups)

c/ Heats allowed to run until the latest 2am (allows either 3-5 more heats or less heats the next day)

d/ Semi-finals 3 minutes long. (saves 24 min per class)

e/ Production finals 8x5 minutes (saves approx 3

hours) f/ No qualifying in Production (saves approx 2 h 30 min)

g/ Number of practicing rounds cut from 8 to 4 (saves 5 hours per class)

1.7 Registration

Non ranked ISRA drivers cannot register for the Worlds by themselves. They need to be introduced by their national delegate (see list on the ISRA website)

For racers without a national delegate or from a new country, please contact an official ISRA officer (see contacts ISRA website) before signing up.

The organizer should install an easy registration system. He also must keep an up to date listing of entrants.

When all registration requirements are completed, a confirmation must appear on the organizers official website.

1.8 Entry fees

The maximum entry fee is Euro 35 per class. The cost of the handout parts in the team race must not be higher than the parts' normal retail prices.

1.9 ISRA driver's licenses

The ISRA driver's license fee is Euro 10 per year.

1.10 ISRA points

The ISRA points are awarded on a falling scale as:

50-45-40-36-32-29-26-24-22-20-18-16-14-12-11-10-9-8-7-6-5-4-3-2 (for the first 24 drivers).

The 25th will receive 1 point, the 26th 0.99, 27th 0.98 and so on.

The top 4 qualifiers in the individual races receive bonus ISRA ranking points on a falling scale (4, 3, 2, 1) to be added to their total from the race.

A driver's ISRA ranking is based on the total of points the driver has collected over the last three ISRA Worlds events.

An entrant with no prior ISRA ranking will be given a ranking number based on enrolment and the first enrolled is given the lowest number beyond drivers with ranking points.

1.11 Trophies

[Up](#)

Prizes are given to all finalists in the sprint races, and to all drivers in the top 8 teams in the production team race.

1.12 Racing principles

The number of marshals must be the same during the whole race. In the first group that is run, marshalling will be done by the drivers of group A. Drivers from the first group will be the marshals for the next group, and so on.

Only during the actual race time or qualifying, are drivers and/or their pit crew permitted to work on their cars. During lane changes, drivers and/or their pit crews may straighten the braids on the car and push in body pins. A specific part of the track will be designated as the pit zone by race direction before the race starts. The driver is allowed to replace her/his car in front of her/him if the car was picked up from there or else it has to be placed in the pit zone. Any car damage that would make the car illegal, such as the loss of a major part of the body or a car dragging the track surface, must be immediately repaired and only during actual race time. The

driver may continue a maximum of 3 laps before stopping to repair the car. An exception in Eurosport 24 and 32 is the loss of a front wheel(s) during the course of racing, and which must be repaired/replaced before the start of a new stage of the race. In Formula 1/32 the loss of a front wheel has to be repaired immediately.

Lane rotation is fixed as follows: 1 - 3 - 5 - 7 - 8 - 6 - 4 - 2 (Red -Green -Blue -Purple -Black -Yellow -Orange -White). Lane change is the driver's responsibility. No compensation can be given for incorrect changing of lanes.

Race direction can temporarily stop the race only if a marshal calls for a stop due to a car; (a) in a non-marshalled position (i.e.: in the middle of the straight in front of the drivers) (b) under a bridge or on the floor in an area indirectly accessible (e.g. under the track) (c) becoming a rider on another lane. The race direction must before the race begins point out which areas of the track that are considered under a and b. Drivers can call for a stop by no other word than "Track!" and only in situations and areas pointed out by the race direction before the race.

The number of laps made can only be the result of the lap counter. No lap correction is made for missed counting due to the car's braids, nor lane jumping (rider) unless caused by a turn marshal placing the car on the wrong lane. Race direction must check the lap counting system if there is a sustained problem. If a problem with the lap counter occurs, then upon its correction, the race direction must re-run the current segment. Drivers will have their cars back only to change wheels and braids.

1.13 Marshalling of cars and counting of laps.

If a car falls off it must be placed back by a turn marshal where it initially left the

slot. The number of laps made can only be the result of the lap counter.

Race direction must check the lap counting system if there is a sustained problem.

The test is made through running across the counter a minimum of ten (10) laps with a test car always available to the race direction.

If a problem with the lap counter is detected, then upon its correction, the race direction must re-run the current segment.

Drivers will have their cars back only to change wheels and braids if the driver so wish.

Lap corrections are made for missed counting in the two following and explicit scenarios only;

a. A car is a rider. The driver, a turn marshal or the race controller call TRACK. In the process of turning the power off the car passes the lap counter.

Only if the turn marshals closest to the lap counter and/or the race direction see the incident and review it as a missed lap, the car shall be placed before the lap counter.

b. A car flies across the lap counter during a crash in the lap counter area. The driver, a turn marshal or the race controller call TRACK.

Only if the turn marshals closest to the lap counter and/or the race direction see the incident and review it as a missed lap, the car shall be placed before the lap counter.

2. Track and speed controllers.

This section presents rules concerning the track and speed controllers for the Worlds organisers' to abide.

2.1 Track

2.2 Lap counter

2.3 Speed controllers

2.4 Pre-ISRA WC practice

2.5 Track wiring and power

2.6 ISRA control principles

2.1 Track

Each ISRA race must be run on a professionally built wooden track with 8 lanes, installed in a reasonable, comfortable and accessible place. Safety arrangements, in the form of track sidewalls, must be used to prevent crash damages. A track must be at least 35 metres long (115 feet) and the distance between lanes must be a minimum of 104mm (4.1 inches). The distance between sidewalls and the outside lane must be a minimum of 150mm (6 inches). Slot width must be 3-4mm and slot depth at least 9mm. Lanes must be signed with colours and/or numbers. The track must have a flat surface. This should be measured by a 300 mm long leveller in two ways. First so that the banking angle is minimized (less than 5 degrees) by positioning the leveller in the direction of the radius, and second that joins and else is less than 1 mm from perfectly flat when measured with the 300 mm leveller held in the driving direction.

Every worlds track shall be re-braided within 12 months prior to the event.

2.2 Lap counter

An electronic lap counter system accurate to within 1/1000 of a second must be used. The track has to be divided into 100 equal sections that are easy readable. The lap counter must be in a position where the chance of cars passing outside of the slot is minimal. In case of need the Race jury may decide to change the lap counter position. The lap counter position must be clearly

visible to the race controller.

The lap counter area has to be marked on the track 1 meter before the lap counter till the end of lap counter.

2.3 Speed controllers

Speed controllers are unrestricted, but they must not raise or store voltage. The controllers' connection to the track must be done with 4mm banana plugs or alligator clips. National sockets are optional.

2.4 Pre-ISRA WC practice

The racetrack shall be closed for practice and competition four weeks prior to the Worlds event. Only the host club racers or raceway customers are allowed to practice.

2.5 Track wiring and power

The track wiring and the power supply must be capable of feeding continuous power of 150W per lane. The cross section of track braid or rail must be 2,5mm² (AWG13) or more. The distance between supply cable points must not exceed 12m (40ft) (i.e. on a 45 meter track there must be at least 4 supply points on each lane). The cross section of supply cables must be 6mm² (AWG10) or more. All track braid joints must be secured with additional clamping (braid-braid butt contact is not sufficient).

When power supplies are used, the following limits shall be obliged: The track power supply must have a regulated output to keep the voltage equal during all segments of a race (practice, qualifying, heats and semi-finals of a class). If the track has a power supply for each lane, the devices must be identical. The capacity of the power supplies must be at least 125A. The track voltage must always be 12.5 - 13.0V DC (unloaded).

When batteries are used, the following limits shall be obliged: At least two sets of batteries with a capacity of at least 500 Ah must be available. A charger of a minimum of 100A must be available. The batteries must not be charged while in use for racing. Track voltage must always be 12.0 - 13.5V DC (unloaded).

Track voltage must be equal during all segments of a race (practice, qualifying, heats and semi-finals of a class) An indicator showing the voltage, must be accessible to all racers during the event.

2.6 ISRA control principles

[Up](#)

60 days prior to a ISRA world championship the ISRA technical officer has to check with the organisers of the event that all technical specifications regarding track, wiring, power supplies and lap counter system is in line with what is specified in the ISRA rulebook.

At the start of the Worlds event, the ISRA technical officer together with the Race Jury and the Race controller will inspect all above mentioned aspects of the track. In case of that the inspection finds problems needed to be attended to, the organisers will have to do it immediately.

This group will also check the fulfilments of seals and stamps to prevent tampering of the hand-out parts.

3. Event procedure

This section rules the organisation and running of an ISRA Worlds event.

[3.1 Prior to race procedures](#)

[3.1.1 Practice](#)

[3.1.2 Track conditioning](#)

[3.1.3 Enclosed park and technical inspection](#)

[3.2 Production race procedure \(1/24 production\)](#)

[3.2.1 Team/Driver Seeding](#)

[3.2.2 Qualifying](#)

[3.2.3 Racing](#)

[3.3 Sprint race procedure](#)

[3.3.1 Stage 1: Qualifying](#)

[3.3.2 Stage 2 - 4: Racing](#)

3.1 Prior to race procedures

An ISRA Worlds event consists of four classes run in the sequence; Production 1/24 team race, 1/32 Eurosport sprint race, 1/32 Formula 1 sprint race, and 1/24 Eurosport sprint race. THE ORGANIZER MUST FOLLOW THIS RACE ORDER The racing starts in the first Saturday of the race week and each class is run completely from start to end including practice before the next class starts.

In line with section 1.5, Number of entries, a schedule is prepared by the organiser. The basic schedule for the 104 entries' limit is presented in section 1.6. At close of registration, when the actual number of registered drivers is known an updated schedule is presented. A schedule must maintain as much practice time as possible.

3.1.1 Practice

A "practice session" represents the minimum amount of practice (minimum 3 minutes on each lane in each class) that can be taken by one entrant at one time on a single lane. At the end of each practice session, that entrant must marshal the following practice session.

Before each class, the organiser must provide regulated practice. Prior to the Production 1/24 team race a minimum of 2 rounds of 8 lanes of preferably 4 minutes each, and a minimum of 3 minutes each. Prior to each sprint race regulated practice has to be 1 round of 8 lanes of preferably 4 minutes each, and a minimum of 3 minutes. These practice sessions are scheduled, based on the ISRA Drivers' ranking. The length of each practice session will be the maximum duration possible as based on the number of entries. Each class will practice separately from the others, no exceptions. Practice is regulated, so that every entrant will have the same amount of practice time.

3.1.2 Track conditioning

The track must be cleaned and spray glued by race direction before the start of open practice. Entrants or drivers cannot alter the track surface condition in any way, only the track braid/strip may be cleaned. Only the race direction may modify the track condition, upon the authorisation of the Race Jury. Drivers may clean only the braid/strip on their own lane before qualifying or the beginning of a stage. Car braid cleaning/conditioning liquids can never be used on the track at any time but by the Track maintenance manager on instructions from the Race direction.

ISRA suggests the organiser to a/ use a glue mixture of two (1 oz) bottles heavy glue into three litres of solvent, and to b/ only spray glue in the turns and a maximum of one metre onto a straight.

3.1.3 Enclosed park and technical inspection

[Up](#)

The pit area (parc fermé) must be enclosed from everyone except the officials responsible for its function. The enclosed park must be a restricted area with the provision of safe storage for the cars in order to avoid any possible damage to them. Drivers and the public must not at any time have access to the area. The organisers are responsible for the security of the area. Cars must remain in the Enclosed Park after the technical inspection, during the qualifying session and during every stage of the racing.

For qualifying, all cars must be brought to the technical inspection impound during the announced open period of time for each class. A technical inspection of the cars based on all eligible rules will begin at the start of that period. This period ends 20 minutes past each practice group's last practice session. All legal cars will be marked by the technical inspectors (engraving on chassis and stamp on body) and be ready to qualify. All non-legal cars will be returned to the entrant. These entrants will be given to the end of the announced open period to make their cars legal. Cars deemed illegal by the end of that period will be technically inspected during race time and if passed the entrant becomes a driver.

The service breaks between the heats and the semi-finals, and between the semi-finals and the final, have the duration of 30 minutes. The technical inspection is open during the service break. All cars have to be on the technical inspection table by the latest at the end of the 30 minute period. All legal cars will be deemed ready to continue racing. All non-legal cars will be returned to the drivers if time is still available. These drivers will be given to the end of that service break to make their cars legal. The track has its power turned on during the breaks. Only the race car may be used.

A car that has been found faulty in the technical inspection may be repaired during the warm up. The car must be re-checked after the repair during the warm-up or after the start, but before making any race laps. A technical inspector must be available at the starting line for the car(s) to be checked as quickly as possible. While the repairing of a faulty car must not delay the start of the race, the inspection may be fulfilled during the start process.

Ground clearance is measured in technical inspection, if you change tires during the warm up, clearance (minimum .8mm), tire width and rear track width will be re-measured before the start of the race. If the widths or clearance is illegal it has to be repaired immediately, but during racing time.

Cars may be randomly checked at any time in a segment. Any part of the car that deviates from the dimensional rule limits must be repaired during actual race time. Those dimensions are; (a) wheel width, (b) overall car width, and (c) rear car height. In the production team race all cars will be re-inspected after their heat. The following points are checked: a) blueprint on motor (the motor may be opened); b) the stamp on the body; c) the blueprint and rubber of the tires; d) the engraving of and intentional structural changes made to the chassis. Any tampering found results in the disqualification of the drivers of the team regardless of if the car has passed an earlier inspection during the race.

Cars that have had their body, tires or gear changed during racing shall always have its dimensions (widths and heights) checked in the next lane change following the repairs. The technical check shall not inflict on the drivers lane change time. If the width or height is illegal it has to be repaired immediately, but during racing time.

The tools that are used during the technical inspections shall be available to drivers during other times than inspection periods. All car dimensions are measured on a recessed tech block.

3.2 Production Race Procedure (1/24 Production)

3.2.1 Team/Driver Seeding

The production race is a 2-person team race, with each team member driving equal amounts. The race shall run as two stages; qualifying and groups.

The ranking of the teams is based on the ISRA drivers' ranking. The best ranking of the two drivers is used. The qualifying starts with the team with highest ranking number, then the next highest and so on.

3.2.2 Qualifying

Qualifying is run over 1 minute where the team with the longest distance covered wins. Each member of a team must drive 30 seconds. A 15 seconds stop for driver change is provided.

3.2.3 Racing

There is no warm up prior to race start in Production.

Each group will consist of 8 segments. Each segment will be 7,5 minutes. If possible, the number of teams in each group should be equal. If not, the number of teams can be one less in the first few groups. Drivers, at the end of their group, must be the corner marshals in the next group.

After each group, a team's finishing position will be a result of the sum of the laps completed, the last lap sections and the result from qualifying. At an eventual tie the number of race laps shall decide.

3.3 Sprint race procedure

Sprint races are conducted in the following classes: Eurosport 1/32; Formula 1 1/32 and Eurosport 1/24. All sprint races consist of four stages; qualifying, heats, semi-finals and a final.

3.3.1 Stage 1: Qualifying

[Up](#)

Qualifying is the first stage of a race. It will be for one minute per driver, on a qualifying lane as chosen by the race direction. Qualifying order will be based on the ISRA Drivers ranking. In all sprint classes, the highest ranked drivers will qualify last. Overall ranking will be determined by the best single lap time as attained by each driver. For two drivers having matching lap times, their second best time will break the tie. Every driver, who misses his or her qualifying time, will be classed in the last position.

All drivers will be placed into stage 2, i.e. the heats sorted by their qualifying result.

A driver may check and straighten her/his braids while on deck, however the car has to be placed on the track by an official.

3.3.2 Stage 2 - 4: Racing

[Up](#)

Stage 2, heats driven 8x3 minutes: The racers qualified at positions 1-8 will race in the last heat, drivers qualified at positions 9-16 in the second last heat, and so on. If possible, the number of drivers in each heat shall be equal. If not, the number of drivers can be one less in the first few groups.

Stage 3, semi-finals driven 8x4 minutes: The best 24 drivers (by lap total) from stage 2 will be placed into 3 semi-finals (A, B and C). The top 8 will be placed in semi A. The next eight will be placed in semi B and the remaining 8 in semi C, which is run first followed by B and A.

Stage 4, final driven 8x5 minutes: The best 8 drivers (by lap total) from stage 3 will move in to the final.

Starting lanes will be chosen by race direction in all stages except stage 4, where the starting lanes will be selected by the racers in an order determined by the results from stage 3. Best result gets first choice.

Depending on the number of drivers, the length of the stages may change to fit reasonable race duration, as determined by race direction. Leading up to the first segment a 1 minute warm-up shall be run on the starting lane.

4. Technical Specifications

This section regards all technical specifications to be scrutinised during technical inspection. They are presented class by class.

All dimensions are in millimetres (mm)

A recessed tech block (guide and rear wheels) is used when measuring the car dimensions except ground clearance.

Only one guide flag device per car is allowed.

The racer is responsible for his car, and it must be legal at all times, even if it was passed through tech inspection, penalties may be imposed for cars found to be illegal.

4.1 1/24 Production

4.1.1 Dimensions

4.1.2 Chassis

4.1.3 Body

4.1.4 Motor

4.1.5 Front wheels and axle

4.1.6 Rear tires, rear axle and bushings

4.2 1/32 Eurosport

4.2.1 Dimensions

4.2.2 Chassis

4.2.3 Body

4.2.4 Motor

4.2.5 Front wheels

4.2.6 Rear tires

4.3. 1/32 Formula 1

4.3.1 Dimensions

4.3.2 Chassis

4.3.3 Body

4.3.4 Motor

4.3.5 Front wheels

4.2.6 Rear tires

4.4 1/24 Eurosport

4.4.1 Dimensions

4.4.2 Chassis

4.4.3 Body

4.4.4 Motor

4.4.5 Front wheels

4.4.6 Rear tires

4.1 1/24 Production

4.1.1

Car

Max height at rear wing	35.0
Max width excluding body pins and tape	83.0
Max height from track surface to bottom of bumper	12,7
Min height at bottom of windscreen	23.0
Min vertical edge at front	1.0
Min ground clearance under rear axle and between rear tires	0.8

Wheels and axles

Max rear tire width	20.7
---------------------	------

Min rear axle diameter	2.36
Min distance from top of rear axle to bottom of chassis	8.6
Min front wheel diameter	12.7
Min front wheel width	0.8
Min front axle diameter	1.0
Min front wheel track	72.0

4.1.2 Chassis

The following chassis are permitted by ISRA in their approved shape and structure:

CHAMPION (USA)
420 Turbo Flex Chassis

PARMA (USA)
595 Flexi 2 Chassis

JK X25 The motor brace supplied with the chassis can be used, and used only on the rear side of motor. It can be used with or without the tube or wire mentioned in g/.

The following modifications are allowed:

- a/ Lead may be taped or glued to the top of the chassis.
- b/ Tape may be added to the top of the chassis.
- c/ The front axle may be soldered to the chassis.
- d/ Front wheel retainers may be soldered to the front axle.
- e/ Pintubes may be added in the original body mounting holes and be either floating or fixed to the chassis.
- f/ Rear oilites may be soldered to the chassis.
- g/ The motor may be soldered to the chassis using a tube or a wire placed on the rear axle side of the motor, however it must be mounted below the rear axle.
- h/ A U-shape piano wire, maximum 1.6, is allowed to reinforce the pillow blocks (uprights)
- i/ Only plain steel non hollow axles are allowed

4.1.3 Body

The body must be mounted as intended and cover the chassis, including the rear tires and the guide flag, in at least one unforced position. It can be fixed to the chassis with pins, clips and/or sellotape. Body decoration is unrestricted, but must be made in at least two different colours. The body must be completely opaque. Windows must be left clear and all four wheels must be completely visible when viewed from the side. Pin striping and/or bodyline detailing is mandatory. The best ranked driver's licence number must be displayed in at least 3 different positions. All cars must have the hand-out interior in the original cockpit position and block any view of the chassis seen from above.

Body cutting must maintain every detail of the real car (i.e. lights, wheel position, etc.) and have the form as produced by the manufacturer.

The organizer will hand out two bodies to each team.

One body for the race and one body for practise, only one body may be teched in for the race.

4.1.4 Motor

The motor is a sealed handout Group 12 motor and is to be used as supplied. However, the motor shaft may be shortened and the can only may be trimmed to provide axle clearance.

4.1.5 Front wheels and axle

The front axle must be straight and pass through the original hole as intended by the manufacturer. The front wheels must be mounted to the axel, turn on their centre at a 90 degree angle to the track surface, and have a black rubber/ plastic perimeter.

4.1.6 Rear tires, rear axle and bushings

Handout tires are used. The rear axle must run in oilites.

4.2 Eurosport 1/32

4.2.1 Dimensions

Car

Max height at rear wing	32.5
Max width excluding body pins and tape	64.0
Min vertical edge at front	1.0
Min ground clearance under rear axle and between rear tires	0.8

Wheels and axles

Max rear tire width	16.0
Min rear tire diameter	15.0
Min front wheel diameter	12.7
Min front wheel width	0.8
Min front wheel track	56.0

Chassis

Max length; centres of rear axle and guide pivot hole	105.0
---	-------

4.2.2 Chassis

Chassis are unrestricted except for the following limitations: - The front wheels must be positioned in the correct wheel arch position in relation to the body approved at the time.

4.2.3 Body

Eurosport 1/32 is a single body class.

Legal body for 2010-2011 is Red Fox (Brazil) Audi Lmp. (See also section 6 for homologation and submitting rules.)

The body must not deviate from its shape as produced by the manufacturer.

The body must cover the entire chassis, including the rear axle and guide flag, in at least one unforced position. It can be fixed to the chassis with pins or sellotape.

Body decoration is unrestricted, but must be made in at least two different colours. The body must be completely opaque. Windows must be left clear and all four wheels must be completely visible when viewed from the side. Pin striping and/or bodyline detailing is mandatory. The driver's licence number must be displayed in at least 3 different positions.

All cars must contain a painted and 1/32 scaled three-dimensional interior with the driver's helmet, shoulders, arms and the steering wheel mounted in the original cockpit position. No portion of the chassis must be seen through the cockpit area when viewed from above. Body cutting must maintain every detail of the real car (i.e. lights, wheel position, etc.).

Two bodies per car are permitted, provided that they are painted, trimmed and mounted identically. The extra body is kept in the enclosed park and made available on the return of the other. During a service break both bodies are available to the driver.

4.2.4 Motor

No restrictions.

4.2.5 Front wheels

The front wheels must turn on their centre at 90 degrees angle to the track surface and have a black rubber/plastic perimeter.

4.2.6 Rear tires

The rubber portion of the tire contacting the track surface must be black.

4.3 Formula 1 1/32

4.3.1 Dimensions

Car

Max height at rear wing	30.0
Max width excluding body pins and tape	68.0
Min left of rear wing endplate/sidepod (see illustration below)	12.0
Min ground clearance under front wheel support/axle	0.8
Min ground clearance under rear axle and between rear tires	0.8

Wheels and axles

Max rear tire width	16.0
Min rear tire diameter	15.0
Min front wheel diameter	14.0
Min front wheel width	4.0
Max front wheel width	10.0
Min front wheel track	62.0

Chassis

Max length; centres of rear axle and guide pivot hole	110.0
Max width of chassis pan section between pans	52.0
Max length of pans	68.0
Max width in front pans, excl. front wheel supports	34.0

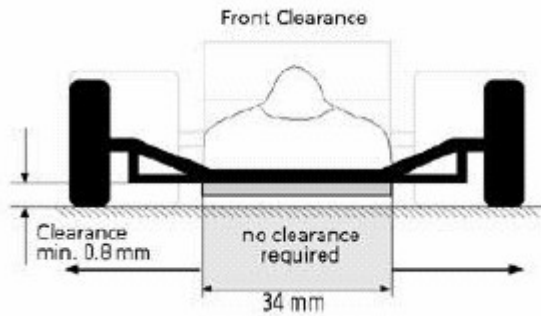

4.3.2 Chassis

Chassis are unrestricted except for the following limitations: The motor must be mounted in the chassis in the "in-line" position (i.e. in a 90-degree angle to the rear axle).

4.3.3 Body

Legal bodies are:

Betta (UK)
 BAR Honda V10 2004
 Betta Williams BMW 2004
 Betta Renault 2006
 Betta Ferrari F110
 Betta McLaren
 Betta Red Bull
 Betta Mercedes MGP

Bolid (Russia)
 BMW Williams

BPA (Czech Republic)
 Ferrari (#040)
 Jordan 199 (#031)
 Williams WF23/BMW (#039)
 McLaren MP 4-17 (#045)
 Jaguar R 4 (#048)
 BAR Honda (#056)
 Toyota TF105 (#064)

RED FOX (BRAZIL)
 F1/GP McLaren 2003
 F1 McLaren 2005
 F1 McLaren 2006

F1/GP Ferrari 2008.1 new version with 3rd element in the front wing (previous version no longer permitted)
 2010 McLaren

CAT (UK)
 Cat Vacs RB08

Only these ISRA approved bodies are permitted. Bodies must be accurate copies of the samples sent to ISRA for homologation (see section 8.1). The body must be maintained in the shape as produced by the manufacturer.

The paint scheme must represent an actual F1-team's car during the last 10 years. Pearl, fluorescent and metallic paints are only allowed if actually a part of an original paint scheme. The major engine cover and sidepod sponsors logo/name must be present. The body must be completely opaque and cover the entire chassis including the guide flag. Excepted are axles, wheels, and the support(s) for the front axle. An additional exception is the rearward portion of the chassis' pans not covered by the body. The chassis portion in this area must be painted black.

The driver's ISRA license number must be displayed in three (3) positions; on both sides of the rear wing and on the front of the car.

All cars must contain a painted and 1/32 scaled three-dimensional interior with driver's helmet, shoulders, arms and steering wheel mounted in the original cockpit position. No portion of the chassis must be seen through the driver area when viewed from above.

Body cutting must maintain every detail of the real car (i.e. wheel position, etc.). Pin striping and/or bodyline detailing is mandatory.

Two bodies per car are permitted, provided that they are painted, trimmed and mounted

identically. The extra body is kept in the enclosed park and made available on the return of the other. During a service break both bodies are available to the driver.

Below is a drawing illustrating the accepted cutting line of the rear wing (greyed area), and where to position the scale logos and driver's ISRA license numbers at the rear.

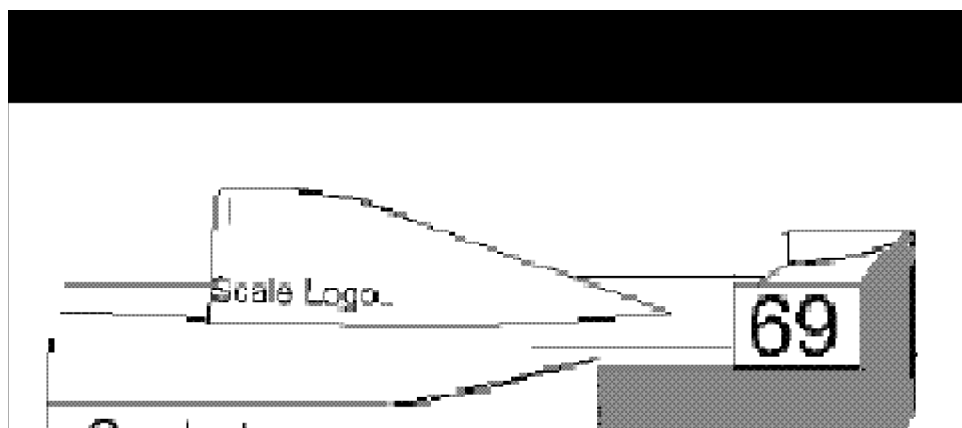

4.3.4 Motor

No restrictions.

4.3.5 Front wheels

They must turn on their centre at 90 degrees to the track surface and have a black rubber/plastic perimeter. The front wheels and their supports must be in the intended position for the approved body used.

4.3.6 Rear tires

The rubber portion of the tire in contact with the track surface must be black.

4.4 Eurosport 1/24

4.4.1 Dimensions

Car

Max height at rear wing	35.0
Max width excluding body pins and tape	83.0
Min vertical edge at front	1.0
Min ground clearance under rear axle and between rear tires	0.8

Wheels and axles

Max rear tire width	20.7
Min rear tire diameter	15.0
Min front wheel diameter	12.7
Min front wheel width	0.8
Min front wheel track	72.0

Chassis

Max length; centres of rear axle and guide pivot hole	125.0
---	-------

4.4.2 Chassis

Chassis are unrestricted except for the following limitations:- the front wheels must be positioned in the correct wheel arch position in relation to the body approved at the time.

4.4.3 Body

Eurosport 1/24 is a single body class.

Legal body for 2011-12 is RedFox (Brazil) Audi LMP. (See also section 8.1 for homologation and submitting rules.)

The body must not deviate from its shape as produced by the manufacturer. The body must cover the entire chassis, including the rear axle and guide flag, in at least one unforced position. It can be fixed to the chassis with pins or sellotape.

Body decoration is unrestricted, but must be made in at least two different colours. The body must be completely opaque. Windows must be left clear and all four wheels must be completely visible when viewed from the side. Pin striping and/or bodyline detailing is mandatory.

The driver's licence number must be displayed in at least 3 different positions.

All cars must contain a painted and 1/24 scaled three-dimensional interior with the driver's helmet, shoulders, arms and the steering wheel mounted in the original cockpit position. No portion of the chassis must be seen through the cockpit area when viewed from above. Body cutting must maintain every detail of the real car (i.e. lights, wheel position, etc.).

Two bodies per car are permitted, provided that they are painted, trimmed and mounted identically. The extra body is kept in the enclosed park and made available on the return of the other. During a service break both bodies are available to the driver.

4.4.4 Motor

No restrictions.

4.4.5 Front wheels

The front wheels must turn on their centre at 90 degrees angle to the track surface and have a black rubber/plastic perimeter.

4.4.6 Rear tires

The rubber portion of the tire contacting the track surface must be black.

5. Local rules

This section is used to present rules and information connected to the local organisation of an ISRA Worlds event. It is updated yearly.

5.1 Production race handouts

The body for the production race is Red Fox Ford Fusion. Two painted and stamped bodies will be handed out. Extra bodies from the same batch will be available to purchase.

5.2 Race direction

The race direction will consist of the following persons:

General manager:

Race Director:

Race Controller:

Technical Inspection: ISRA delegates headed by

Track Management:

Web & Information:

Results manager:

Venue Management:

5.3 Conduct

To be completed by organiser (i.e. smoking and alcohol rules)

6. Product eligibility and homologation principles

THIS SECTION COULD BE REMOVED COMPLETELY AND PUT IN A SEPARATE DOCUMENT FOR SUPPLIERS

This section is providing information to producers of bodies and production chassis which they would like to submit to be eligible for ISRA racing.

6.1 Bodies

6.2 Production chassis

Any manufacturer that wishes to propose a body or production chassis for use in an ISRA event must have 3 copies of the body or production chassis forwarded to ISRA. Information regarding availability, cost and production quantities must accompany the submission.

A person appointed by the ISRA delegates meeting prepares the decisions to add new bodies and production chassis to the current lists. That person also communicate with the producers concerning if their body or production chassis fulfils the specified requirements for approval. At the latest 6 months prior to the final day for submission known manufacturers are invited to take part. The invitation is sent out via e-mail.

Bodies and production chassis for approval must be submitted no later than on the day 30 days prior to the ISRA delegates meeting. Bodies and chassis submitted late will not be considered. Submitted bodies and production chassis will past final date be published with photo at the ISRA website; www.isra-slot.com

The ISRA delegates' meeting makes the final decision on approval.

No changes may be done to a body's or production chassis shape after ISRA homologation. Such modifications will automatically make the altered body or production chassis illegal. Such a modified body or production chassis will be treated as a different product, and should accordingly have a different name/ product number.

6.1 Bodies

[Up](#)

ISRA approves bodies for three classes; Eurosport 1/32, 1/24 and Formula 1 1/32. The bodies are approved on both dimensional and subjective basis. The ISRA delegates' meeting makes the final decision by choosing from those submitted in time.

In the Eurosport classes a body approved will be the single legal body in that class for two subsequent ISRA World Championships starting one year after the approval. In 1/24 the selection is made even years (2006, 2008, 2010 ...) and in 1/32 odd years (2007, 2009, 2011 ...).

F1 1/32 bodies are approved yearly and bodies are added to the list. No manufacturer may have more than ten (10) bodies on the list at any time.

THIS ALSO WILL BECOME SINGLE BODY TO BE CHOSEN IN 2011 TO RACE IN 2012-13

The manufacturer of an approved body must send at least one copy of its body to the organiser of an ISRA WC on request. Bodies that are not available to the organiser will not be accepted in the technical inspection.

6.1.1 Body dimensions

The following dimensions are the basis of acceptance for ISRA racing. However, even if a body complies with these dimensions, it is not automatically accepted but requires subjective scrutineering by the ISRA Delegates. The dimensions will not be used in car inspection.

Formula 1 1/32

Bodies must closely follow the shape and proportions of the actual car. However, there are technical specifications that have to be met illustrated by the drawings below:

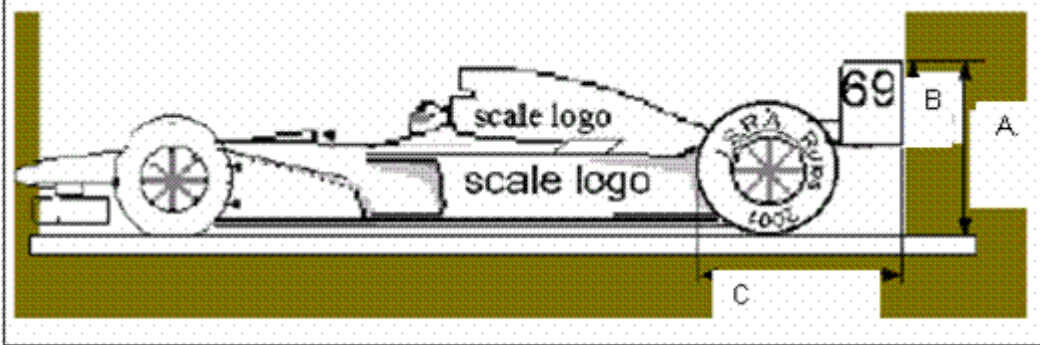

A/ Max height of rear wing mounted on car 30mm

B/ Minimum endplate of rear wing to be left in 12mm

C/ The body is not allowed to cover any portion of the rear wheels. No more than 30mm can be cut out of the side of the body, measured from the back edge of the wing surface to the front of the rear wheels.

D? Max front wing width 58mm

E/ Max width of second element of front wing 12.7mm

F/ Body width in front of the chassis pans must be minimum 34mm to cover the chassis

G/ The body width is max 58mm, but has to be minimum 54mm to cover the chassis pans, which are max 68mm long and 52mm wide

H/ Max width of rear wing 34mm

PLEASE NOTE: The restriction on F1 chassis is a maximum length of 110mm measured from the centre of the rear axle to the centre of the guide pivot hole. The body must cover the entire chassis including the guide. Rear tires, front wheels and their supports may be visible.

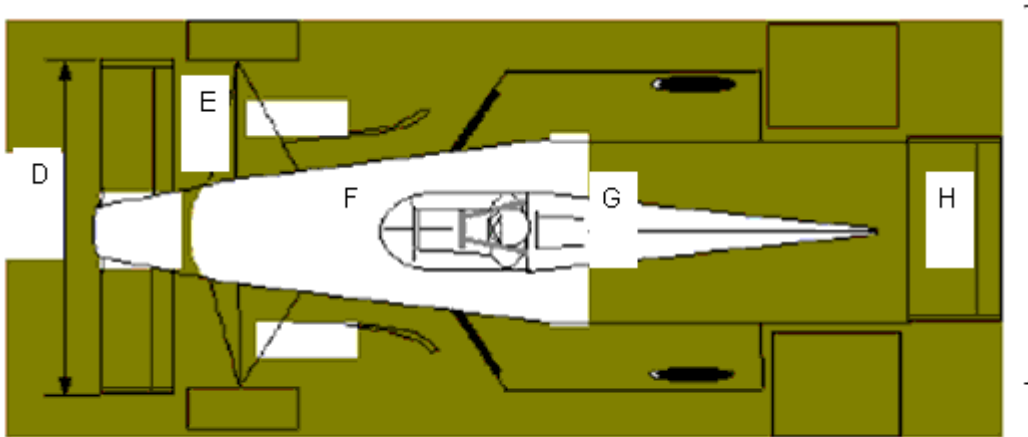

Eurosport 1/32 and 1/24

In Eurosport the bodies follows the dimensional criteria illustrated by the drawing below. All the dimensions are to be measured on a plain and level surface with a recess for the guide and rear wheels.

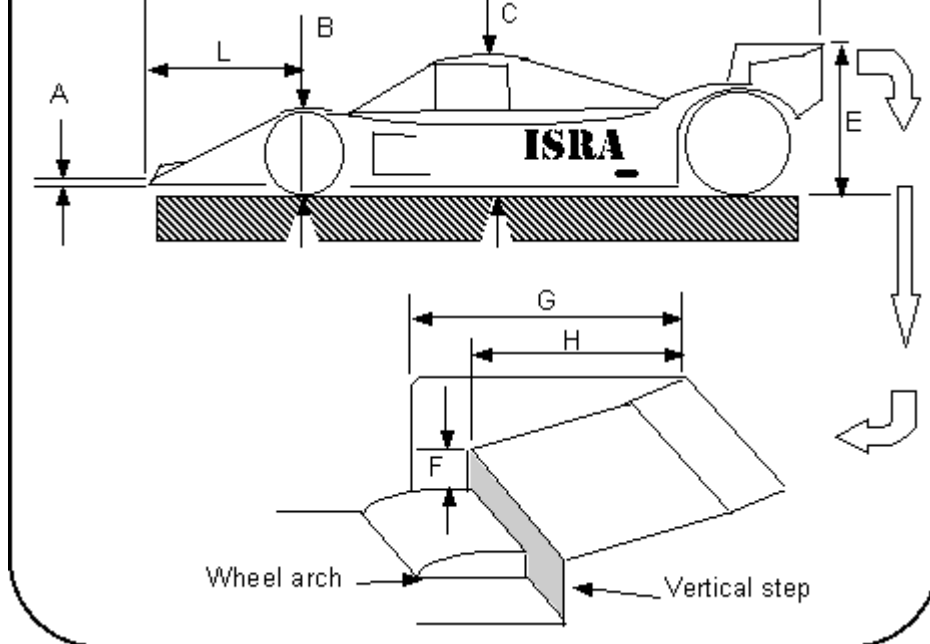

1/32 Eurosport

A	1 mm MIN VERTICAL EDGE
B	13.5 mm MIN 17.5 mm MAX
C	24 mm MIN MEASURED AT ROLL HOOP OR ABOVE WINDOW, EXCLUDES AIR INTAKE.
D	142 mm MAX
E	32.5 mm MAX
F	1.5 mm MIN
G	22 mm MAX
H	20 mm MAX
J	15 mm MIN
K	30 mm MIN MEASURED AT COCKPIT OPENING OR BASE OF WINDOWS
L	37 mm MAX

1/24 Eurosport

A	1 mm MIN VERTICAL EDGE
B	15 mm MIN 18 mm MAX
C	26 mm MIN MEASURED AT ROLL HOOP OR ABOVE WINDOW, EXCLUDES AIR INTAKE.
D	165 mm MAX
E	35 mm MAX
F	2.5 mm MIN
G	30 mm MAX
H	25 mm MAX
J	20 mm MIN
K	40 mm MIN MEASURED AT COCKPIT OPENING OR BASE OF WINDOWS
L	45 mm MAX

6.2 Production chassis

[Up](#)

ISRA approves chassis for one class; Production 1/24. The bodies are approved on a technical basis of a 2-piece stamped steel construction of a maximum length of 120 mm measured between the centre of the real axle and the centre of the guide pivot hole.

Minimum thickness of production chassis is 0.9 mm with 5% manufacturing tolerance.

Since the ISRA rules does not allow any changes to the chassis it is important that the model submitted is of high quality.

A manufacturer may have more than one chassis homologated for ISRA racing.

The ISRA delegates' meeting makes the final decision. Chassis initially not approved by the delegates may be resubmitted with revisions as suggested. Chassis approved will be legal at the ISRA World Championships one year after the approval.

The manufacturer of an approved chassis must send at least one copy to the organiser of an ISRA WC on request. Chassis that are not available to the organiser will not be accepted in the technical inspection.